



SOR

1500 series

mechanical level switches

built
tough

field-proven

dependable under demanding conditions



rugged,
reliable
problem
solvers

1540



The SOR® family of 1500 series mechanical level switches answer industry's call for less expensive alternatives to the traditional chambered switch.

The 1510

Horizontal-mount, float-operated, electric level switch.

The 1540

Horizontal-mount, non-bleed, pneumatic level switch.

The 1530

Horizontal-mount, float-operated, pneumatic level switch.

The 1550

Vertical-mount, float-operated, electric level switch.

The 1520

Vertical-mount, vane-operated electric flow switch.

The 1500s are suitable for most any point level application.

- separators
- suction scrubbers
- dehydrators
- refrigeration
- re-injection
- small diameter vessels
- high-low alarm
- cooling water applications
- wet scrubbers
- seal pots
- make-up water
- vapor recovery
- overflow protection
- lube oil reservoirs
- pump on - pump off
- contaminated water applications

Common 1500 series features and benefits:

- all stainless steel construction
- standard product rating of 1500 psi at 400° F
- minimum working temperature rating of -40° F
- complete isolation of the process from the switch – no o-rings or seals
- horizontal switches may be oriented for high- or low-level action - why stock 2 different switches?
- oh yeah . . . low price

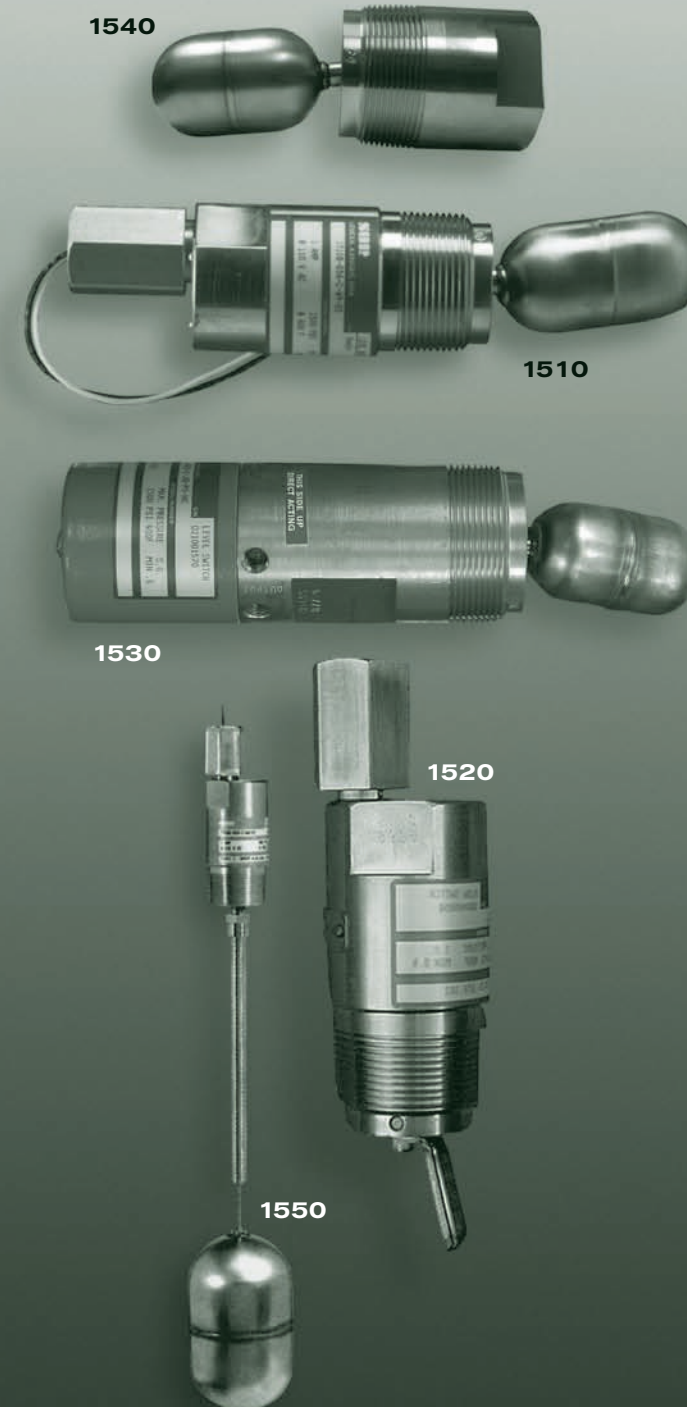

field-proven

SOR 1500 series level switches have conquered the test of time under some of the toughest operating conditions – the oil patch. Designed for harsh and hazardous environments and process materials where tough welds and rugged components are critical, the 1500s are built to take it.



Application: Separators

Multiple separators are a common sight in the natural gas industry. Even with raw gas wells, there is always condensate, water, or some other NGL that needs to be separated prior to transporting it for processing.

There are a number of separation technologies and all of them require collection of these liquids after separation. Some are simple gravity separators, some can be quite elaborate. **Regardless of the separation method, SOR 1500s fit the application.**

simple, reliable solutions

SOR 1500 series mechanical level switches and a generic, horizontal separator process.

Inlet separator

As raw gas from the field enters large vessels in the plant called “inlet separators,” condensate (natural gasoline) and water is removed from the main gas stream. An SOR 1510 level switch is mounted in a separator at, or about, the same elevation as the inlet pipe that brings in combinations of fluids such as oil, water, gas and condensate. A shut-off valve is installed in the inlet piping that is usually kept open by air pressure and allows the fluid mix to enter the vessel. When liquid reaches the float on the 1510, the switch activates.

Upon activation, a signal is sent to (for example) a solenoid valve (sometimes via a PLC) that blocks the air normally routed to the valve. With the air supply cut off, the valve closes and fluid flow to the separator comes to a halt.

When an SOR 1540 is used, the air supply reaches the shut-off valve via the pneumatic level switch. When activated, the air is blocked and the shut-off valve closes because of a lack of air supply.

In both cases, a separate level controller works in conjunction with a dump valve that drains the liquid from the separator.

Blow case separator

Another specific separator application where 1500 series level switches excel is controlling a blowcase separator upstream from a compressor.

A blowcase separator is essentially two vessels connected vertically. Gas flows into the upper vessel (compressor) and gravity pulls liquids down into the lower vessel (blowcase). When the blowcase is full, a 1500 series switch trips and closes a valve between the two tanks. A second valve opens and allows the compressed gas from above back down into the blowcase. This forces the accumulated liquids out into the pipeline – downstream from the compressor.

A second 1500 series switch is often used as a low level to reset the system when the blowcase empties. Both the 1510 and 1540 can be used with equal effectiveness; the one you choose depends only on the application and your preference.

The 1500s are not restricted to collection tanks. They may also be used to control the level of sour applications and/or “sweetening solutions” with the available NACE certification.

Glycol dehydrator

Often, a glycol dehydrator is necessary for removal of tiny water droplets from natural gas if the water was not completely extracted with the separator. The process involves “dehydrating” the natural gas and usually calls for one of two processes: *absorption* or *adsorption*. The 1500 series switches fall into the *absorption* process.

Glycol dehydration involves putting glycol in contact with a stream of natural gas that contains water. The glycol absorbs the water from the wet gas stream, becomes heavier and sinks to the bottom of the contactor where it is expelled. The natural gas is then easily routed out of the dehydrator and the glycol/water solution is sent to a special boiler that steams away the water allowing the glycol to be recycled.

An SOR 1500 series mechanical level switch is installed on the inlet scrubber/contactor/absorber to monitor glycol/water levels. When mounted below the wet gas inlet, it prevents the glycol/water level from

rising above it. If the level reaches the switch, a signal is sent to a solenoid that works in conjunction with a dump valve that drains the liquid from the scrubber/contactor/absorber.

Flash tank separator-condenser

When absorbing water from the wet gas stream, the glycol solution will sometimes pick up small amounts of methane and other compounds. Flash tank separators decrease the losses of these materials before the glycol solution reaches the boiler. The process virtually eliminates the burning and subsequent venting of these closely monitored compounds. SOR 1500 series switches are a popular choice to monitor flash tank levels and to prevent them from reaching a critical point.

keep
intricate
processes
running
smoothly



1510 electric level switch

A horizontally mounted, float-operated level switch suitable for plant and OEM applications where open or closed contacts are required to signal presence or absence of liquid at a discrete level. The float extension arm moves a magnet which actuates or de-actuates a hermetically sealed reed switch. Actuation/de-actuation can be reversed by rotating the unit 180 degrees.

Specifications

Mounting (half coupling only)

Orientation	Horizontal mount only
Connection size	1-1/2" NPT(M) Standard

Maximum Process Pressure 1500 psi (100 BAR)

Electrical

Switch type	Hermetically sealed reed switch with 18" 20 AWG wire leads
Switch rating (resistive)	1 amp at 110 VAC 3 amps at 28 VDC
Relay housing	Class I, Group A, B, C & D; Division 1 & 2
Connection size	1/2" NPT(F)
Contact form	SPST

Minimum Specific Gravity 0.45

Design Code ANSI B31.3

Shipping Weight Approximately 6 lbs. (3 kg)

Agency Listing CSA Certified, ATEX and IECEx approved— see Optional Accessories on page 5, GOST-R

Options

For	Change	To
2" NPT(M)	G5A	G2A
Flanged mounting	G5A	See Optional Flanges at right for designator (316SS only)
SPST	W9	W1



Optional Flanges (316SS construction only)

Designator	Raised Face Flange	
G7C	2.5 inches	150#
G7D	2.5 inches	300#
G7E	2.5 inches	600#
G3C	3 inches	150#
G3D	3 inches	300#
G3E	3 inches	600#
G4C	4 inches	150#
G4D	4 inches	300#
G6C	6 inches	150#
G6D	6 inches	300#

Floats are detached from flanged units for shipping.

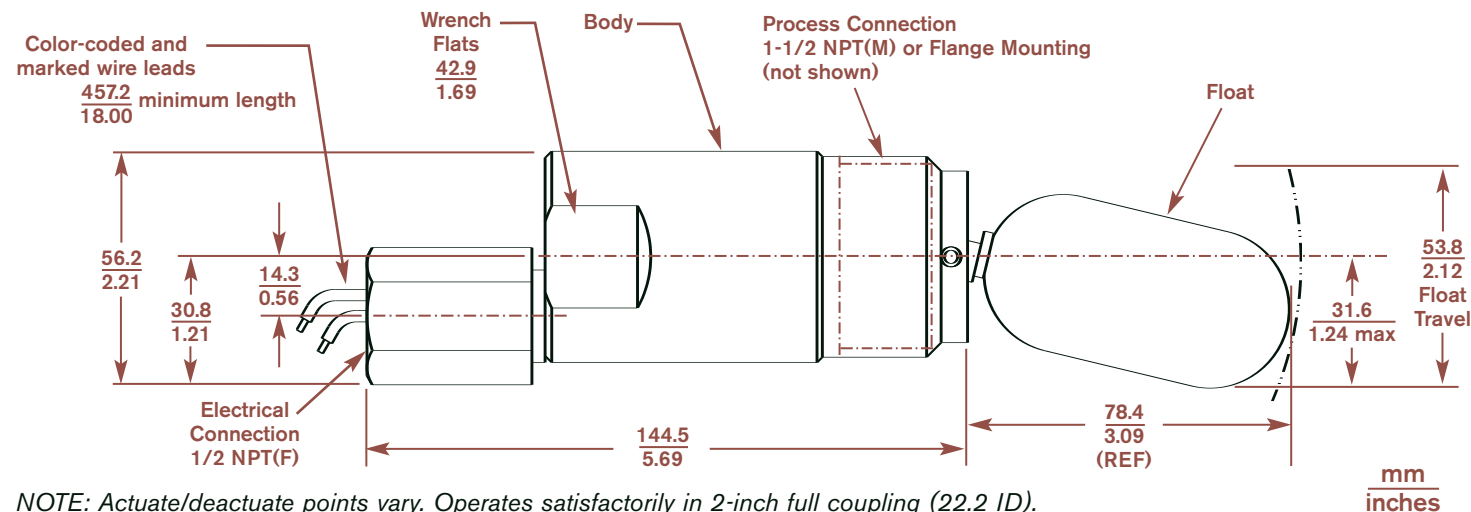

NOTE: Actuate/deactuate points vary. Operates satisfactorily in 2-inch full coupling (22.2 ID).

Optional Accessories

Add option designator(s) to end of model number.

Designator Description

BB	Wetted parts are cleaned for industrial oxygen service.
CL*	ATEX and IECEx approved.
CR	3/4" NPT(F) conduit connection.
CS*	CSA Certified. Class I, Group A, B, C, D; Division 1 & 2. For relay option; Class I, Group C & D, Division 1 & 2.
CV	Canadian Registration Number (CRN). Maximum allowable pressure rating is 1500 psi. Consult the factory for details.
CZ	ANSI B31.3 certificate of conformance.
MC**	Manual check accessory (uses Viton GLT o-rings).
NC	NACE construction - MR-01-75. Available only with 316SS materials of construction.
PP	Tag, fiber. Attached with plastic wire to housing. Stamped with customer-specified tagging information.
RB	24 VDC powered DPDT relay in explosion proof terminal box. Contact rating: 10 amps @ 115 VAC. Class I, Group C, D; Division 1 & 2.
RC	120 VAC powered DPDT relay in explosion proof terminal box. Contact rating: 10 amps @ 115 VAC. Class I, Group C, D; Division 1 & 2.
RR	Tag, stainless steel. Attached with stainless steel wire to housing. Stamped with customer-specified tagging information – 2 lines, 18 characters per line including spaces.
TT	Stainless steel nameplate permanently attached to housing. Stamped with customer specified tagging information.
VV	Fungicidal varnish. Covers exterior except working parts.
YY	Epoxy coating. Exterior only. Polyamide epoxy with 316SS pigment.

*CS or CL option is required on all flange-mounted units.

**Manufacturer limits on Viton GLT are -40 to 400°F.

How to Order

Select model number from the table below. Accessory designator(s) may be added after ES, if required. (See Optional Accessories above.)

Model Number	Body Material	Float Material	Process Rating
1510B-G5A-C-W9-ES	303SS* Standard	316SS (Standard)	1500 psi -40 to 400°F (-40 to 204°C) 100 BAR
1510B-G5A-M-W9-ES		Monel	900 psi -40 to 400°F (-40 to 204°C) 62 BAR
1510B-G5A-S-W9-ES		Polypropylene	5000 psi -40 to 150°F (-40 to 65.5°C) 345 BAR
1510C-G5A-C-W9-ES	316SS	316SS	1500 psi -40 to 400°F (-40 to 204°C) 100 BAR
1510C-G5A-M-W9-ES		Monel	900 psi -40 to 400°F (-40 to 204°C) 62 BAR
1510C-G5A-S-W9-ES		Polypropylene	5000 psi -40 to 150°F (-40 to 65.5°C) 345 BAR

*Also known as ASME SA 320 Grade B8F.

1540 side-mount pneumatic level switch

A horizontally mounted, float-operated level switch suitable for plant and OEM applications where pneumatic valve operation is required to signal presence or absence of liquid at a discrete level. The float arm moves a magnet which, in turn, moves a shuttle that either blocks or allows pilot pressure to pass and operate ancillary equipment. Actuation or de-actuation can be reversed by rotating the unit 180 degrees or by switching inlet connections.

Specifications

Orientation	Horizontal mount only
Connection size	2" NPT(M)
I/O connection	1/4" NPT(F)
Output pressure	0-30 psi (0-2 BAR)
Pilot (supply) pressure	0-30 psi (0-2 BAR)
Flow rate @ 30 psi supply	60 SCFH (.01 CMH)
Leak rate	0.5 SCFH (.01 CMH)
Maximum process pressure	1500 psi (100 BAR)
Minimum specific gravity	0.65
Shipping weight	3.5 lbs. (2 kg)

SCFH – Standard Cubic Feet per Hour
CMH – Cubic Meters per Hour

The supply media must be filtered and oil free. Air is the usual medium, however any dry, filtered gas may be used.

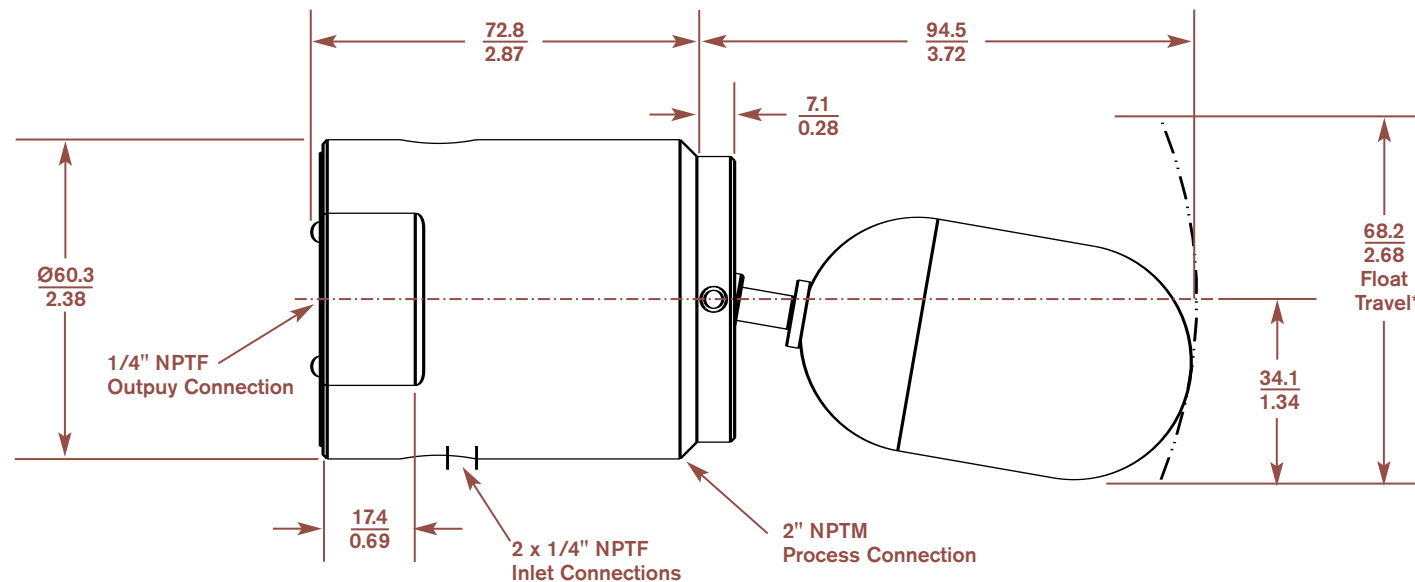
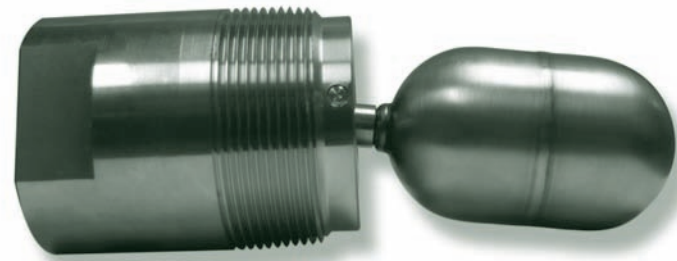

*Actuate/deactuate points vary. Operates satisfactorily in 2-inch full coupling (2.22 ID).

mm
inches

Optional Accessories

Add option designator(s) to end of model number.

Designator	Description
BB	Wetted parts are cleaned for industrial oxygen service.
CV	Canadian Registration Number (CRN).
CZ	ANSI B3.3 certificate of performance.
NC	NACE construction – MR-01-75.
PP	Tag fiber. Attached with plastic wire to housing. Stamped with customer-specified tagging information.
RR	Stainless steel nameplate attached to housing with wire. Stamped with customer-specified tagging information – 2 lines, 18 characters per line including spaces.
TT	Stainless steel nameplate permanently attached to housing. Stamped with customer-specified tagging information.
VV	Fungicidal varnish. Covers exterior except working parts.
YY	Epoxy coating on exterior only. Polyamide epoxy with 316SS pigment.

How to Order

Select model number from the table below. Accessory designator(s) may be added after PS, if required (see Optional Accessories above).

Model Number	Body Material	Float Material	Process Rating
1540C-G2A-C-J0-PS	316SS	316SS	*-40 to 400°F 1500 psi (-40 to 204°C) (100 BAR)

* Manufacturer limits on Viton GLT are -40 to 400°F.

1530 pneumatic level switch

A horizontally mounted, float-operated level switch suitable for plant and OEM applications where pneumatic valve operation is required to signal presence or absence of liquid at a discrete level. The float extension arm moves a magnet that actuates or de-actuates a pilot valve to operate a pneumatic amplifier. Actuation/de-actuation may be reversed by rotating the unit 180 degrees.

Specifications

Mounting

Orientation Horizontal mount only
 Connection size 1-1/2" NPT(M) Standard

For Flanged mounting **Change** G2A **To** See Optional Flanges at right for option designator.

Maximum process pressure 1500 psi (100 BAR)

Supply pressure range 20 to 60 psi (1.4 to 4.1 BAR)

Supply pressure connection size 1/8" NPT(F)

Minimum specific gravity 0.60

Design Code ANSI B31.3

Shipping Weight Approximately 6 lbs. (3 kg)

If supply pressure medium is natural gas, a filter/regulator is suggested on the supply line and the valve vent port should be piped to a safe area.



Optional Flanges (316SS construction only)

Designator	Raised Face Flange	
G7C	2.5 inches	150#
G7D	2.5 inches	300#
G7E	2.5 inches	600#
G3C	3 inches	150#
G3D	3 inches	300#
G3E	3 inches	600#
G4C	4 inches	150#
G4D	4 inches	300#
G6C	6 inches	150#
G6D	6 inches	300#

Floats are detached from flanged units for shipping.

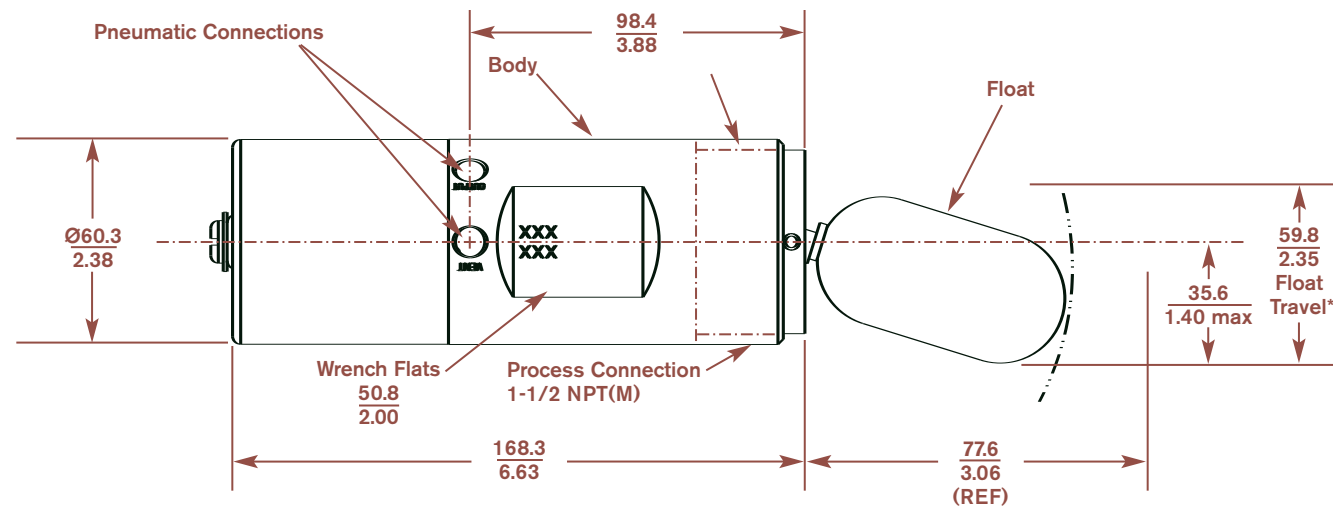

*Actuate/deactuate points vary. Operates satisfactorily in 2-inch full coupling (2.22 ID).

Optional Accessories

Add option designator(s) to end of model number.

Designator	Description
BB	Wetted parts are cleaned for industrial oxygen service.
CV	Canadian Registration Number (CRN) – maximum allowable pressure rating is 1500 psi. Consult the factory for details.
CZ	ANSI B31.3 certificate of performance.
NC	NACE construction – MR-01-75. Available only with 316SS materials of construction.
PP	Tag, fiber. Attached with plastic wire to housing. Stamped with customer-specified tagging information.
RR	Stainless steel nameplate attached to housing with wire. Stamped with customer-specified tagging information – 2 lines, 18 characters per line including spaces.
TT	Stainless steel nameplate permanently attached to housing. Stamped with customer-specified tagging information.
VV	Fungicidal varnish. Covers exterior and interior except working parts.
YY	Epoxy coating. Exterior only. Polyamide epoxy with 316SS pigment.

How to Order

Select model number from the table below. Accessory designator(s) may be added after PS, if required (see Optional Accessories above).

Model Number	Body Material	Float Material	Process Rating
1530B-G2A-C-J0-PS	303SS* Standard	316SS	1500 psi -40 to 400°F (-40 to 204°C) 100 BAR
1530B-G2A-M-J0-PS	303SS*	Monel	900 psi -40 to 400°F (-40 to 204°C) 62 BAR
1530B-G2A-S-J0-PS	303SS*	Polypropylene	5000 psi -40 to 150°F (-40 to 204°C) 345 BAR
1530C-G2A-C-J0-PS	316SS	316SS	1500 psi -40 to 400°F (-40 to 204°C) 100 BAR
1530C-G2A-M-J0-PS	316SS	Monel	900 psi -40 to 400°F (-40 to 204°C) 62 BAR
1530C-G2A-S-J0-PS	316SS	Polypropylene	5000 psi -40 to 150°F (-40 to 204°C) 345 BAR

NOTE: Maximum temperature for polypropylene is 150° F.

* Also known as ASME SA 320 Grade BBF.

1550 vertical electric level switch

A vertically mounted float-operated level switch suitable for plant and OEM applications where open or closed contacts are required to signal presence or absence of liquid at a discrete level. The float stem moves a magnet that actuates or de-actuates a hermetically sealed reed switch.

Specifications

Mounting (half coupling only)

Orientation	Vertical mount only
Connection size	1-1/2" NPT(M) Standard

For	Change	To
2" NPT(M)	F5A	F5A
Flanged mounting	F5A	See Optional Flanges at right for designator – 316SS construction only

Maximum process pressure 443 psi (30.5 BAR) @ 100° F (38° C)

Process temperature range -40 to 400° F (-40 to 204° C)

NOTE: Housing is not submersible in processes above 320° F (160° C).

Electrical

Switch type Hermetically sealed reed switch with 18" 20 AWG wire leads

Switch rating (resistive) 1 amp at 110 VAC
3 amps at 28 VDC

Housing Class I, Groups C & D; Divisions 1 & 2

Relay housing Class I, Groups C & D; Divisions 1 & 2

Connection size 1/2" NPT(F)

Contact form SPST – for SPDT change W9 to W1 in model number

Minimum specific gravity 0.60 based on 16" insertion insertion depth L – see drawing at right

Minimum insertion depth L
Full coupling 5" (13 cm)
Half coupling 7" (17.8 cm)
5.25" (13.3 cm)

Maximum insertion depth L 48" (122 cm)

Minimum specific gravity @ 48" (122 cm) 0.69

Design Code ANSI B31.3

Shipping Weight Approximately 5 lbs. (2.2 kg)

Agency Listing CSA Certified, Class 1, Groups A, B, C, D; Divisions 1 & 2 – for relay option: Class 1, Groups C & D; Divisions 1 & 2; ATEX and IECEx approved, GOST-R

Optional Flanges

316SS construction only. All flanges are seal-welded to bodies.

Designator	Raised Face Flange	
F7C	2.5 inches	150#
F7D	2.5 inches	300#
F7E	2.5 inches	600#
F3C	3 inches	150#
F3D	3 inches	300#
F3E	3 inches	600#
F4C	4 inches	150#
F4D	4 inches	300#
F4E	4 inches	600#
F6C	6 inches	150#
F6D	6 inches	300#
F6E	6 inches	600#

Floats are detached from flanged units for shipping.

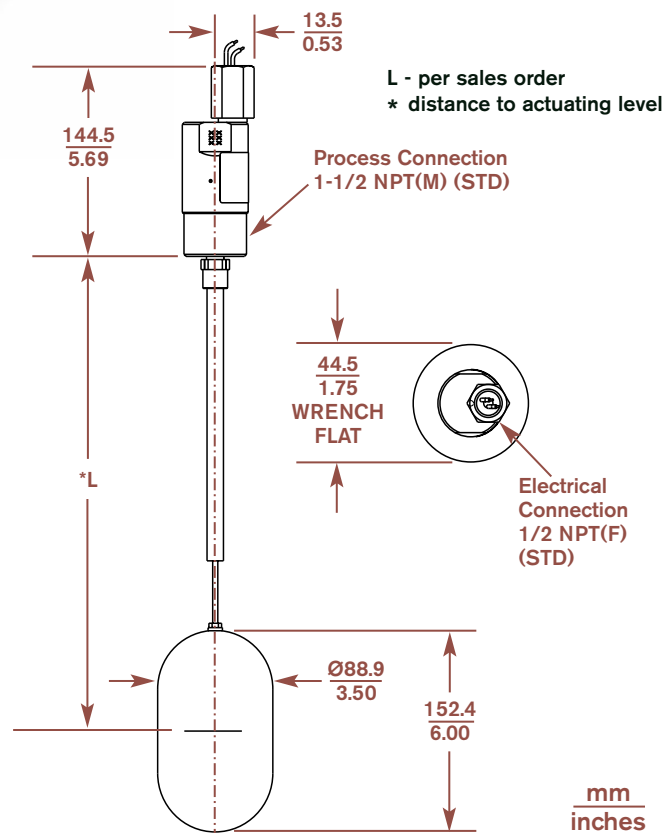

Optional Accessories

Add option designator(s) to end of model number.

Designator Description

BB	Wetted parts are cleaned for industrial oxygen service.
CL*	ATEX and IECEx approved.
CR	3/4" NPT (F) conduit connection.
CS*	CSA certified Class I, Group A, B, C, D, Division 1 & 2 Relay option – Class I, Group C & D Division 1 & 2
HT	Explosion-proof terminal box CSA certified. Class I, Group A, B, C, D Class II, Group E, F, G Class III, Division I (NEMA 4X)
NC	NACE construction – MR-01-75. Available only with 316SS materials.
PP	Tag, fiber. Attached with plastic wire to housing. Stamped with customer specified tagging information.
RB	4 VDC powered DPDT relay in explosion-proof terminal box. Contact rating: 10 amps @ 115 VAC Class I, Group D; Division 1 & 2.
RC	120 VDC powered DPDT relay in explosion-proof terminal box. Contact rating: 10 amps @ 115 VAC Class I, Group D; Division 1 & 2.
RR	Tag, fiber. Attached with stainless steel wire to housing. Stamped with customer-specified tagging information – 2 lines, 18 characters per line including spaces.
TT	Stainless steel nameplate permanently attached to housing. Stamped with customer-specified tagging information.
VV	Fungicidal varnish. Covers exterior and interior except working parts.
YY	Epoxy coating. Exterior only. Polyamide epoxy with 316SS pigment.

*CS or CL option is required on all flange-mounted units.

How to Order

Select model number from the table below. Accessory designator(s) may be added after PS, if required (see Optional Accessories above).

Model Number	Body Material	Float Material	Process Rating
1550C-F5A-C-W9-ES	316SS	316SS	443 psi (30.5 BAR)
1550C-F5A-M-W9-ES	316SS	Monel	265 psi (18.2 BAR)

- Customer to specify insertion depth L for each switch – see drawing at left.
- Stem guides not installed on units with insertion depth L less than 7" (177.8 mm).
- 3.5" (90 mm) diameter float will not fit through many process connections.
- Float may need to be attached from inside the vessel after instrument installation.

1520 electric flow switch

A vertically mounted, vane-operated flow switch suitable for plant and OEM applications where open or closed contacts are required to signal flow or no-flow conditions. The vane extension arm moves a magnet that actuates or de-actuates a hermetically sealed reed switch.

Specifications

Mounting

Orientation	Vertical mount only
Connection size	1-1/2" NPT(M) Standard

For	Change	To
2" NPT(M)	F5A	F5A
Flanged mounting	F5A	See Optional Flanges below for designator – 316SS construction only

Maximum process pressure 1500 psi (100 BAR)

Process temperature range -40 to 400° F (-40 to 204° C)

Electrical

Switch type	Hermetically sealed reed switch with 18" 20 AWG wire leads
Switch rating (resistive)	1 amp at 110 VAC 3 amps at 28 VDC
Housing	Class I, Group A, B, C, D; Division 1 & 2
Optional relay housing	Class I, Group C, D; Division 1 & 2

Minimum flow rate 1 FPS

Design Code ANSI B31.3

Shipping Weight Approximately 6 lbs. (3 kg)

Agency Listing CSA Certified, ATEX and IECEx approved – see Optional Accessories on page 13, GOST-R

Optional Flanges (316SS construction only)

Designator	Raised Face Flange	
F7C	2.5 inches	150#
F7D	2.5 inches	300#
F7E	2.5 inches	600#
F3C	3 inches	150#
F3D	3 inches	300#
F3E	3 inches	600#
F4C	4 inches	150#
F4D	4 inches	300#
F4E	4 inches	600#
F6C	6 inches	150#
F6D	6 inches	300#
F6E	6 inches	600#

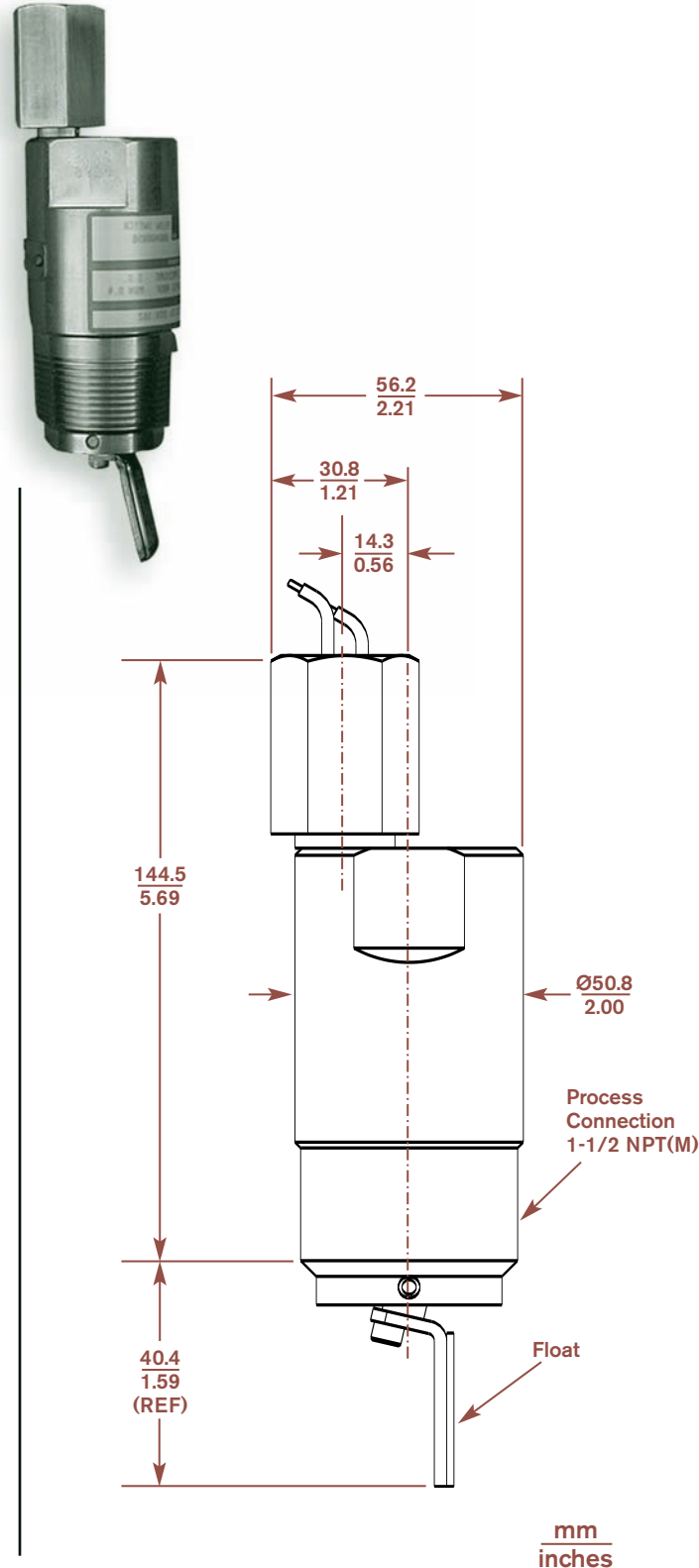

Optional Accessories

Add option designator(s) to end of model number.

Designator	Description
BB	Wetted parts are cleaned for industrial oxygen service.
CL*	ATEX and IECEx approved.
CR	3/4" NPT(F) conduit connection.
CS*	CSA certified. explosion proof, Class I, Group C & D when used with RB or RC relay optional accessories. CSA certified explosion proof Class I, Group A, B, C, D.
CV	Canadian Registration Number (CRN) – process ratings may be affected. Consult the factory for details.
HT	Explosion-proof terminal box CSA certified.
NC	NACE construction – MR-01-75. Available only with 316SS materials.
PP	Tag, fiber. Attached with plastic wire to housing. Stamped with customer specified tagging information.
RB	24 VDC powered DPDT relay in explosion-proof terminal box. Contact rating: 10 amps @ 115 VAC. Class I, Group C, D; Division 1 & 2.
RC	120 VDC powered DPDT relay in explosion-proof terminal box. Contact rating: 10 amps @ 115 VAC, Class I, Group C, D; Division 1.
RR	Tag, stainless steel. Attached with stainless steel wire to housing. Stamped with customer-specified tagging information – 2 lines, 18 characters per line including spaces.
TT	Stainless steel nameplate or separate stainless steel tag. Permanently attached to housing. Stamped with customer-specified tagging information.
VV	Fungicidal varnish. Covers exterior and interior except working parts.
YY	Epoxy coating. Exterior only. Polyamide epoxy with 316SS pigment.

*CS or CL option is required on all flange-mounted units.

How to Order

Add option designators to end of model number.

Model Number	Body Material	Vane Material
1520B-F5A-C-W9-EF	303SS*	316SS (Standard)
1520C-F5A-C-W9-EF	316SS	316SS

* Also known as ASME SA 320 Grade B8F

popular add-ons

Manual Check

Available on 1510 electric level switch only.

The original 1500 was born from customer input and SOR continues the tradition by offering a manual check option for the 1510 electric level switch. The optional Manual Check allows the user to verify switch integrity without removing the 1510 from the vessel or increasing or decreasing liquid levels. This is particularly useful for systems testing in safety applications, such as a manual override, where the switch is not called upon very often. It can also be used as a method to manually trigger a valve or activate the normal function the switch.

Many customers are mandated by regulatory authorities to include this type of function. Others just like the added functionality and peace of mind the Manual Check provides.



The 1510 Manual Check option is activated by turning the knob located on the side of the switch body. When the "N" or neutral indicator is oriented towards the permanently-stamped guide marker, the unit is in normal operating mode. Turning the knob clockwise or counterclockwise (depending on whether the switch is performing a high- or low-level function) manually moves the float and changes the switch state. NOTE: always re-turn the knob to the neutral position before leaving the switch.

Whatever your application, the Manual Check option provides added functionality to the SOR 1510 without compromising pressure or temperature ratings.



Chambers

Available for all 1500 series level switches.

Customers often ask SOR to use its machining and welding expertise to make small chambers that go with the 1500s they purchase. Thanks to a major expansion of the SOR manufacturing facilities, we now offer ANSI quality chambers for use with the 1500 series products at a competitive price.

Flexible processes make it possible for us to offer chambers for both 1-1/2 and 2-inch body 1500 series products, as well as a wide range of available process connections. Whether you require the standard 1-inch NPT or even flanged connections, SOR can make it happen. Just give us your requirements and we're off and running.

With chambers from SOR you can consolidate vendors and buy from a name you have trusted for many years.

Contact your local SOR representative for more information about SOR chambers and Manual Check.

Replacement Parts

SOR manufactures and maintains a supply of replacement parts for its 1500 series level switches.

Part Number	Description
1510	
3130-091	SPST Hermetically Sealed Reed Switch Capsule
3130-242	SPDT Hermetically Sealed Reed Switch Capsule
3130-106	SPST Hermetically Sealed Reed Switch Capsule for CSA Certified units
3130-243	SPDT Hermetically Sealed Reed Switch Capsule for CSA Certified units
3130-052	316SS Float Assembly
1540	
922701 1	Pneumatic sensor assembly
3100152	Float
9227012	Float and arm assembly
1530	
3130-114	Pneumatic relay assembly
3130-052	316SS Float assembly
1550	
3130-091	SPST Hermetically sealed reed switch capsule
3130-242	SPST Hermetically sealed reed switch capsule
3130-106	SPST Hermetically sealed reed switch capsule for CSA certified units
3130-243	SPDT Hermetically sealed reed switch capsule for CSA certified units
3101-132	316SS Float (consult the factory for other materials)
3130-396	Actuator replacement kit
1520	
3130-091	SPST Hermetically Sealed Reed Switch Capsule
3130-242	SPDT Hermetically Sealed Reed Switch Capsule
3130-106	SPST Hermetically Sealed Reed Switch Capsule for CSA Certified units
3130-243	SPDT Hermetically Sealed Reed Switch Capsule
3130-118	316SS Vane Assembly
3130-403	Actuator Arm Replacement Kit (1-1/2" NPT and flanged process connections)
3130-404	Actuator Arm Replacement Kit (2" NPT process connection)

All 1500 series mechanical level switches come with a 5 year warranty

SOR agrees to repair or replace any switch found to be defective in material or workmanship within five years from date of shipment. The limited warranty is valid only if the switch was installed in accordance with published factory installation instructions, operated within the design limitations stated on the nameplate and returned to the factory for inspection, freight prepaid, within the warranty period. Contact the factory for return authorization. No claim for labor or consequential damages will be allowed.

NOTE: Designs and specifications are subject to change without notice. For latest revisions see www.sorinc.com.

**custom
engineered
to fit your
application**

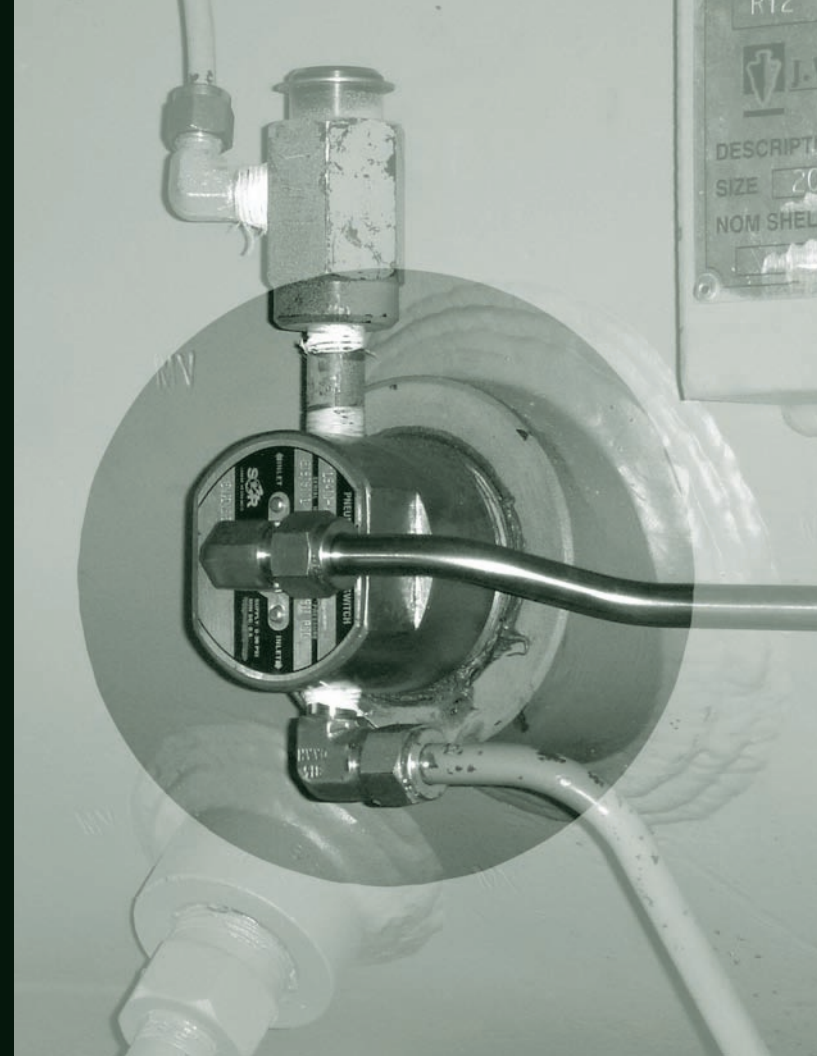

**rugged,
reliable
problem
solvers**

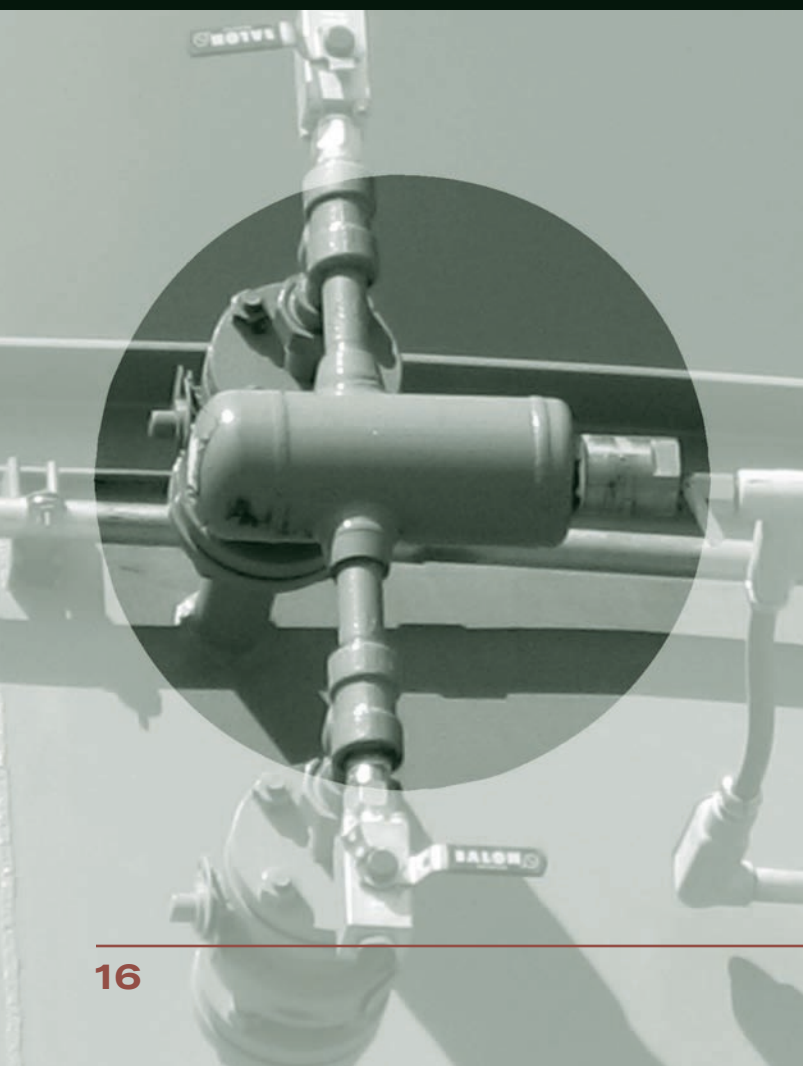

SOR has a registered quality system to ISO 9001:2000. World headquarters are located in Lenexa, Kansas USA with satellite offices in the United Kingdom and China. SOR supports its markets with more than 120 sales representatives worldwide. To find a representative near you, please visit www.sorinc.com.

SOR® offers a full line of commercial-grade process instruments.

**echOsonix™
Level Transmitters**



**Level
Switches**



Level

**Temperature
Switches**



**Flow
Switches**



Flow

Temperature Pressure

**Pressure
Switches**



Process Instrumentation

We Deliver Quality On Time

SOR Inc.

14685 West 105th Street
Lenexa, Kansas 66215
Phone 913-888-2630

Toll Free 800-676-6794
Fax 913-888-0767

www.sorinc.com
www.echOsonix.com



M&D CONTROLS, INC

4142 South 70th East Avenue
Tulsa, Oklahoma 74145-4605

Tulsa- (918)664-7511 Fax (918)622-7035 WATS 800-824-3818
email- manddcontrols@aol.com

Registered Quality System to ISO 9001: 2000

Form 1378 (01.08) ©2008 SOR Inc.