

# DUAL-LINE FLOW RATE/TOTALIZERS

## ProVu • Model PD6200 Analog Input



**PROVU**  
SERIES

### Analog Inputs

- 0-20 mA, 4-20 mA, 0-5 V, 1-5 V, and  $\pm 10$  V Inputs
- Isolated 24 VDC @ 200 mA Transmitter Power Supply
- Open Channel Flow with Programmable Exponent
- Square Root Extraction
- 32-Point Linearization

### COMMON METER FEATURES

- NEMA 4X, IP65 Front
- Universal 85-265 VAC or 12/24 VDC Input Power
- Large Dual-Line 6-Digit Display, 0.60" & 0.46"
- Programmable Displays & Function Keys
- Sunlight Readable Display
- 2 or 4 Relays + Isolated 4-20 mA Output Options
- External 4-Relay & Digital I/O Expansion Modules
- RS-232, RS-422/485 Serial Communication Options
- -40 to 65°C Operating Temperature Range

### COMMON RATE/TOTALIZER FEATURES

- Display Rate & Total at the Same Time
- Rate in Units per Second, Minute, Hour, or Day
- Total, Grand Total or Non-Resettable Grand Total
- Password Protection for Total Reset
- 9-Digit Totalizer with Total Overflow Feature
- Total Stored in Non-Volatile Memory
- Any Relay for Rate or Total
- 4-20 mA Output for Rate or Total
- Sampling Relay

## ProVu • Model PD6300 Pulse Input



### Pulse Inputs

- Pulse, Open Collector, NPN, PNP, TTL, Switch Contact, Sine Wave (Coil), Square Wave Inputs
- 5, 10 or 24 VDC Flowmeter Power Supply
- Gate Function for Rate Display of Slow Pulse Rates
- K-Factor, Internal Scaling, or External Calibration
- 4-20 mA Output Option Converts the Pulse Input to an Isolated 4-20 mA Output



**PERFECT FOR FLOW APPLICATIONS**

The PD6200 and PD6300 ProVu meters are 1/8 DIN flow rate/totalizers specifically designed for displaying flow rate and total from flowmeters with analog or pulse outputs. These flow rate/totalizers are particularly well-suited for flow applications because they can display flow rate and flow total at the same time, provide power to drive the flowmeter, and display flow total, flow grand total, or non-resettable flow total on up to nine digits.

**FRONT PANEL DISPLAY**

**Display Flow Rate, Total or Grand Total**

The main display can be programmed to display flow rate, total, or grand total, and the secondary display can be programmed to display flow rate, total, grand total, engineering units, custom legends, or can be turned off. Both displays could also display relay set points, or max and min values.

In the graphic at the top of the page, the main display is displaying flow rate (as indicated by the "R" to the right of the number) and the secondary display is displaying flow total (as indicated by the "T" under the number.) The following photographs show typical ways these flow rate/totalizers can be programmed.



**Totalizer Overflow Displays Total to 9 Digits**

These flow rate/totalizers can display up to nine digits of total flow with the total overflow feature. In the diagrams below, the flow totalizer is displaying 532,831,470 by toggling between a display of "oF 532" and "831470". Notice the (T with arrow ▲ symbol) is lit up indicating the display is in overflow mode.



**Environmentally Tough**

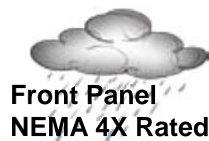

**Rugged**

A unique front panel design makes the ProVu nearly impenetrable in typical applications. Here, the ProVu easily survives a direct hit on the display from a heavy 2" solid stainless steel ball dropped from eight feet.



## TOTALIZER CAPABILITIES

These ProVu flow rate/totalizers can be programmed for a wide variety of totalizer applications. They can display total, grand total, or non-resettable grand total with a time base of seconds, minutes, hours or days. The user can program a totalizer conversion factor, a non-resettable grand total, password protection, and several total reset methods.

### Non-Resettable Grand Total

The user can set up the grand total to be non-resettable by entering a specific password. Once this is done, the grand total can never be reset.

### Totalizer Conversion Factor

The user can enter a totalizer conversion factor that allows the meter to display total in different units than the rate. For instance, a customer could measure flow rate in gallons per minute and total in hundredths of acre-feet.

### Password Protection

The total and grand total can be password protected so they can be reset only by authorized personnel.



Total Password



Grand Total Password

### Front Panel Total Reset

The three front panel function keys can be programmed to reset the total and grand total. This makes it possible for the user to reset either the total or the grand total by pressing the appropriate function key. Of course, if the total or grand total is password protected, they will not reset when the function key is pressed.



### Remote Total Reset

An I/O expansion module can be used to remotely reset the total or grand total. The reset switch is wired into the module and the module is connected to the M-Link RJ45 connector at the back of the flow rate/totalizer.

### Total Alarms

The ProVu's four internal and four external relays can be set up to alarm when the total reaches a user-defined set point. A variety of reset modes are available and the user can also program time delays and fail-safe operation.

## FIELD EXPANSION MODULES

Add functionality to the ProVu in the field with easy-to-install external expansion modules. Add RS-232 or RS-422/485 communications, I/O modules (up to 2), or 4-relay expansion module. The menu items for these modules do not appear until the module is connected, simplifying the basic menu. Relay and digital I/O modules are shown below with optional DIN rail mounting kit, P/N PDA1002.

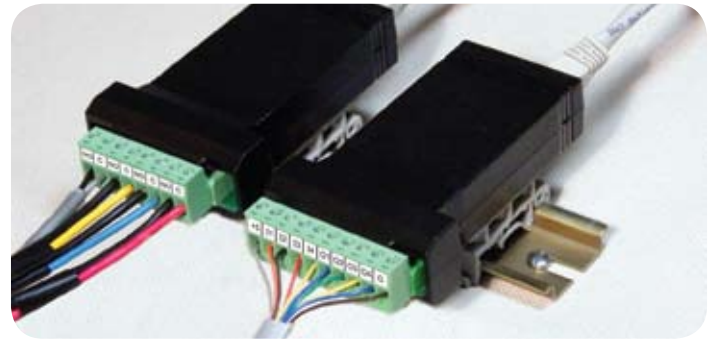

### I/O Expansion Module

Four digital inputs and four digital outputs are available per expansion module. The ProVu meter will accept two of these modules. External digital inputs can function similarly to the front panel function keys. They can be configured to trigger certain events (i.e. reset total or grand total, acknowledge/reset alarms, reset max and/or min values, disable/enable all output relays, hold current relay states), and provide direct menu access point.

Digital outputs can be used to remotely monitor ProVu's alarm relay output states, or the states of a variety of actions and functions executed by the meter.

### Relay Expansion Module

An external module containing four 3 amp Form A (SPST) relays can be added to the ProVu at anytime. Removable screw terminal blocks accept 12 to 22 AWG wire.



### Communications Module

Serial communications on the ProVu can be added anytime with external RS-232 or RS-422/485 communication adapters.



## OUTPUTS

### Relay Outputs

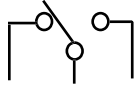

The **ProVu** has up to four 3 A Form C relays (SPDT), giving you more fail-safe options upon power loss. Relay action can also be configured for input loop break protection. Set ON and OFF time delays when needed. Up to eight front panel indicators show alarm and/or relay state. All relays can be configured for 0-100% deadband.

### Relay Operation & Configuration

There are powerful relay functions that can be configured in the **ProVu** meter, including:

- Automatic reset only (non-latching)
- Automatic + manual reset at any time (non-latching)
- Latching (manual reset only)
- Latching with clear (manual reset only after alarm condition has cleared)
- Sampling (activated for a user-specified time)
- User selectable fail-safe operation
- Relay action for loss (break) of 4-20 mA input signal
- Time delay (on and off), independent for each relay
- Manual control mode

### Analog Output

The isolated analog retransmission signal can be configured to represent the rate, total, grand total, maximum (peak) value, minimum (valley) value, or the value for any of the eight relay set points. While the output is nominally 4-20 mA, the signal will accurately accommodate ranges from 1 to 23 mA.

### Auto/Manual Control

Take control of any output with this feature. All relays can be forced ON or OFF, and the 4-20 mA output signal can be set to any value within its range. This is particularly useful for valve control applications.

### Isolated Transmitter Power Supplies

A powerful 24 V @ 200 mA power supply is a standard feature on the **ProVu** meter. It can be configured for 5, 10, or 24 V (default) by means of a simple internal jumper (see manual). An additional power supply (24 V @ 40 mA) is standard with the 4-20 mA output option.

## NEMA 4 & 4X FIELD ENCLOSURES

Plastic, stainless steel, and painted steel NEMA 4X enclosures for up to 10 **ProVu** meters.



PDA2811



PDA2706

See our complete offering at [www.predig.com](http://www.predig.com)

## EASY PROGRAMMING AND SETUP

### Dual-Line Display & 4 Buttons

The user friendly dual-line display and four programming buttons make the **ProVu** easy to set up and program. The four buttons keep the user in control of the programming process, and the second line provides a reminder or prompt for the current programming step.



Input 1



Display 1

The meter on the left is prompting the user to enter the desired input value, which in this case will be 4 mA. A key feature of the **ProVu** is that it is not necessary to actually apply this input to the meter because it can be scaled without a calibrator.

The meter on the right is prompting the user to enter the desired display value that corresponds to Input 1. The right arrow ► moves the active digit to the right and the up arrow ▲ increases the value of the digit.

### I/O Module for Remote Programming

The I/O module can be used to program the **ProVu** remotely, in essence giving the user control of the four front panel push buttons. This feature is particularly useful if the meter is mounted inside an explosion-proof enclosure.

## METER COPY

The Copy feature is used to copy (or clone) all the settings from one **ProVu** to other **ProVu** meters **in about 20 seconds!** The Copy function is a standard feature on all meters. It does not require a communications adapter, only an optional cable assembly, P/N PDA1200. See the ordering information for complete details.



Copying Meter Settings

**APPLICATIONS**

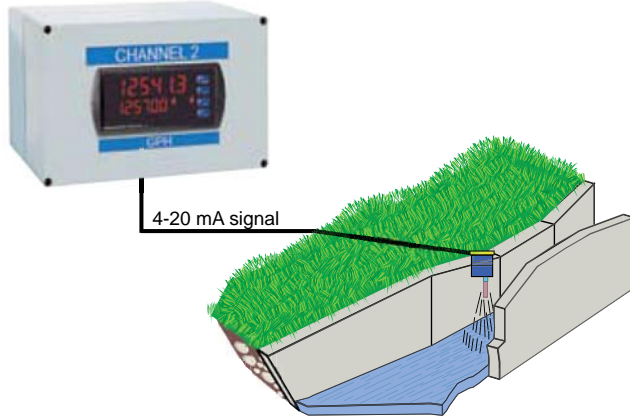

**Open Channel Flow**

The PD6200, in combination with an ultrasonic level transmitter, makes for an economical way to measure and display open channel flow rate and total in most weirs and flumes and take periodic samples. All the user needs to do is enter the exponent for the weir or flume into the PD6200 and the PD6200 automatically raises the input signal to that power. Sampling can be based on the total flow or the flow rate. For instance, to display open channel flow rate and total from a 3 inch Parshall flume and take a one pint sample every 100,000 gallons, the user would program the PD6200 as follows:

Function	Desire	Programming
Open Channel Flow	3" Parshall flume	Set Programmable Exponent to 1.547
Flow Rate	Millions of Gallons per Day (MGD)	Set 4 mA = 0 & 20 mA = 3.508 Time base = Day
Total	Millions of Gallons	Set Totalizer Conversion Factor = 1 (password protect total reset)
Non-Resettable Grand Total	Program meter so grand total can never be reset	Set non-resettable grand total password
Display	Display Flow Rate and Total at the same time	Set main display for Grand Total and secondary display to toggle between rate and total.
Sampling	Take a 1 pint sample every 100,000 gallons	Set up relay for sampling and to trip every 0.1 million gallons. Set up sampling time such that 1 pint is sampled.

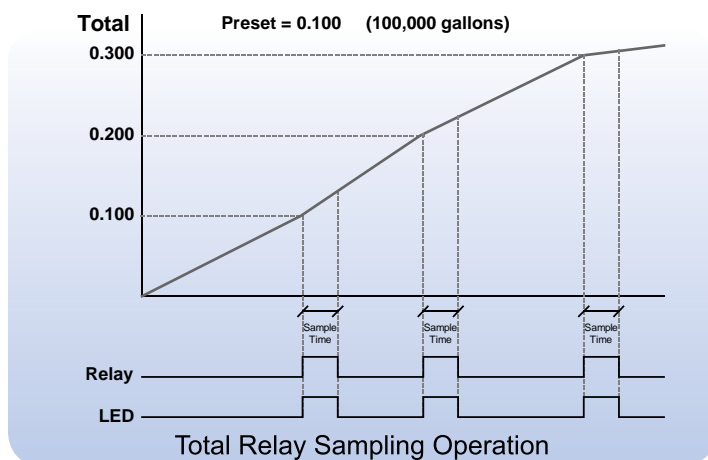

**Differential Pressure Flow**

The PD6200 can display flow rate and total by extracting the square root from the 4-20 mA signal from a differential pressure transmitter. The user selectable low-flow cutoff feature gives a reading of zero when the flow rate drops below a user selectable value.

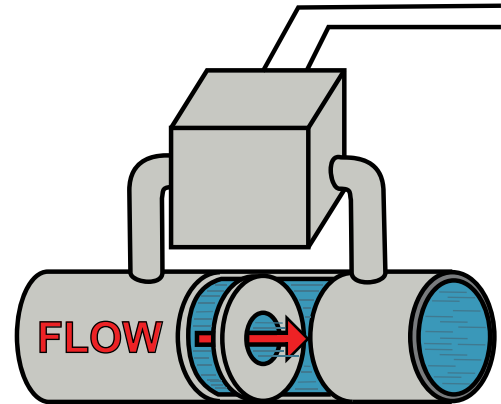

- Display Flow Rate
- User Selectable Low-Flow Cutoff
- Only 2 Calibration Points Required

**Convert Pulse to 4-20 mA with PD6300**

The PD6300 accepts the pulse output from a flowmeter and with the appropriate option installed can convert the pulse to a 4-20 mA signal. The 4-20 mA signal can be programmed to correspond to either the flow rate or the total flow.

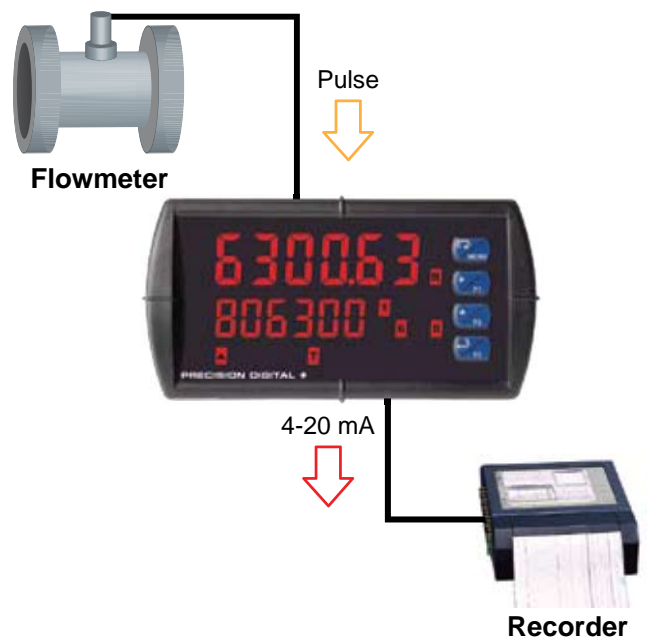

- Use K-Factor or Multi-Point Scaling
- ProVu Powers the Flowmeter
- Display Flow Rate & Total

**CONNECTIONS**

**PD6200**

- Form C (SPDT) relays
- Two isolated power supplies available even on 12/24 VDC input power models
- Removable terminal blocks
- 2 or 4 relays + isolated 4-20 mA output option

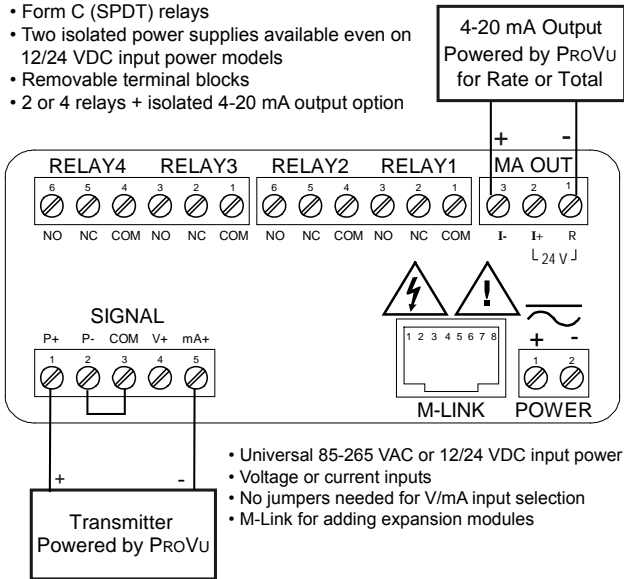

**PD6300**

- Form C (SPDT) relays
- Two isolated power supplies available even on 12/24 VDC input power models
- Removable terminal blocks
- 2 or 4 relays + isolated 4-20 mA output option

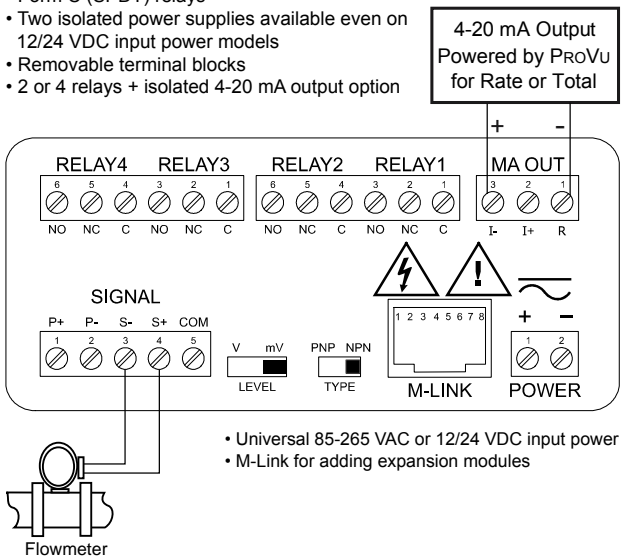

**MOUNTING DIMENSIONS**

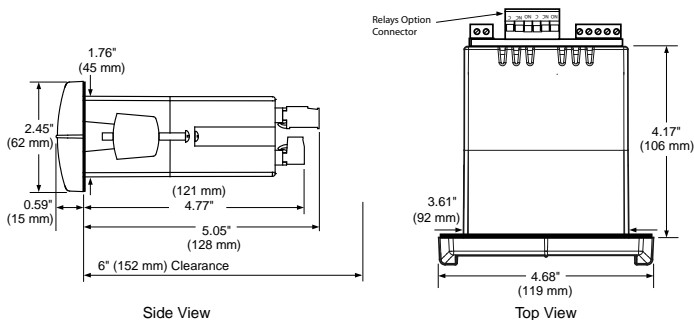

**Notes:**

1. Panel cutout required: 1.772" x 3.622" (45mm x 92mm)
2. Panel thickness: 0.040 - 0.250" (1.0mm - 6.4mm)
3. Mounting brackets lock in place for easy mounting
4. Clearance: Allow 6" (152 mm) behind the panel



**SPECIFICATIONS**

Except where noted all specifications apply to operation at +25°C.

**General**

**Display:** Main display: 0.60" (15 mm) high, second display: 0.46" (12 mm) high. Both displays are 6 digits (-99999 to 999999), red LEDs with leading zero blanking.

**Display Intensity:** Eight user selectable intensity levels

**Overrange:** Display flashes 999999

**Underrange:** Display flashes -99999

**Front Panel:** NEMA 4X, IP65

**Programming Methods:** Four front panel buttons, digital inputs, PC and multi-point linearization utility, or cloning using Copy function.

**Recalibration:** All ranges are calibrated at the factory. Recalibration is recommended at least every 12 months.

**Max/Min Display:** Max (Peak) / min (Valley) readings reached by the process are stored until reset by the user or until power to the meter is turned off.

**Password:** Three programmable passwords restrict modification of programmed settings and two prevent resetting the totals. Pass 1: Allows use of the F1-F3 function keys. Pass 2: Allows use of the F1-F3 function keys and changing the set/reset points. Pass 3: Restricts all programming and F1-F3 keys. Total: Prevents resetting the total manually. Gtotal: Prevents resetting the grand total manually.

**Non-Volatile Memory:** All programmed settings are stored in non-volatile memory for a minimum of ten years if power is lost.

**Power Options:** 85-265 VAC 50/60 Hz, 90-265 VDC 20 W max, or jumper selectable 12/24 VDC ±10%, 15 W max.

**Fuse:** Required external fuse: UL Recognized, 5 A max, slow blow; up to 6 meters may share one 5 A fuse.

**Isolated Transmitter Power Supply:** Terminals P+ & P-: 24 VDC ± 10% @ 200 mA max (standard), (12/24 VDC powered models rated @ 100 mA max). 5 or 10 VDC @ 50 mA max, selectable with internal jumper J4.

**Isolation:** 4 kV input/output-to-power line. 500 V input-to-output or output-to-P+ supply.

**Environmental:** Operating temperature range: -40 to 65°C. Storage temperature range: -40 to 85°C. Relative humidity: 0 to 90% non-condensing.

**Connections:** Removable screw terminal blocks accept 12 to 22 AWG wire, RJ45 for external relays, digital I/O, and serial communication adapters.

**Enclosure:** 1/8 DIN, high impact plastic, UL 94V-0, color: black

**Mounting:** 1/8 DIN panel cutout required: 3.622" x 1.772"

(92 mm x 45 mm). Two panel mounting bracket assemblies are provided.

**Tightening Torque:** Screw terminal connectors: 5 lb-in (0.56 Nm)

**Overall Dimensions:** 4.68" x 2.45" x 5.64" (119 mm x 62 mm x 143 mm) (W x H x D)

**Weight:** 9.5 oz (269 g)

**UL File Number:** UL & c-UL Listed. E160849; 508 Industrial Control Equipment.

**Warranty:** 3 years parts & labor

## PD6200 Analog Inputs

**Inputs:** Field selectable: 0-20, 4-20 mA,  $\pm 10$  VDC (0-5, 1-5, 0-10 V)

**Accuracy:**  $\pm 0.03\%$  of calibrated span  $\pm 1$  count, square root & programmable exponent accuracy range: 10-100% of calibrated span

**Display Update Rate:** 5/second (200 ms)

**Temperature Drift:** 0.005% of calibrated span/ $^{\circ}$ C max from 0 to 65 $^{\circ}$ C ambient, 0.01% of calibrated span/ $^{\circ}$ C max from -40 to 0 $^{\circ}$ C ambient

**Math Function:** Linear, square root, programmable exponent, or round horizontal tank volume calculation.

**Multi-Point Linearization:** 2 to 32 points

**Programmable Exponent:** 1.0001 to 2.9999

**Low-Flow Cutoff:** 0-999999 (0 disables cutoff function)

**Decimal Point:** Up to five decimal places or none: d.ddddd, dd.dddd, ddd.dd, dddd.d, or dddddd.

**Calibration Range:** Input range: 4-20 mA,  $\pm 10$  V. Minimum span: 0.15 mA or 0.10 V. An Error message will appear if input 1 and input 2 signals are too close together.

**Input Impedance:** Voltage ranges: greater than 1 M $\Omega$ . Current ranges: 50 - 100  $\Omega$  (depending on resettable fuse impedance).

**Input Overload:** Current input protected by resettable fuse, 30 VDC max. Fuse resets automatically after fault is removed.

**Noise Filter:** Programmable from 2 to 199 (0 will disable filter)

**Filter Bypass:** Programmable from 0.1 to 99.9% of calibrated span

**Normal Mode Rejection:** Greater than 60 dB at 50/60 Hz

## PD6300 Rate Inputs

**Inputs:** Field selectable: Pulse or square wave 0-5 V, 0-12 V, or 0-24 V @ 30 kHz; TTL; open collector 4.7 k $\Omega$  pull-up to 5 V @ 30 kHz; NPN or PNP transistor, switch contact 4.7 k $\Omega$  pull-up to 5 V @ 40 Hz.

**Low Voltage Mag Pickup (Isolated):** 40mVp-p to 8Vp-p

**Minimum Input Frequency:** 0.001 Hz -> Minimum frequency is dependent on high gate setting

**Maximum Input Frequency:** 30,000 Hz (10,000 for Low Voltage Mag Pickup)

**Input Impedance:** Pulse input: Greater than 300 k $\Omega$  @ 1 kHz. Open collector/switch input: 4.7 k $\Omega$  pull-up to 5 V.

**Accuracy:**  $\pm 0.03\%$  of calibrated span  $\pm 1$  count

**Display Update Rate:** Total: 10/sec, Rate: 10/sec to 1/100 sec

**Temperature Drift:** Rate display is not affected by changes in temperature.

**Multi-Point Linearization:** 2 to 32 points

**Low-Flow Cutoff:** 0-999999 (0 disables cutoff function)

**Decimal Point:** Up to five decimal places or none: d.ddddd, d.dddd, d.ddd, d.dd, d.d, or dddddd

**Calibration:** May be calibrated using K-factor, scale using internal calibration, or calibrate by applying an external calibration signal.

**K-Factor:** Field programmable K-factor converts input pulses to rate in engineering units. May be programmed from 0.00001 to 999,999 pulses/unit.

**Calibration Range:** Input 1 signal may be set anywhere in the range of the meter; input 2 signal may be set anywhere above or below input 1 setting. Minimum input span between any two inputs is 10 Hz. An Error message will appear if the input 1 and input 2 signals are too close together.

**Filter:** Programmable contact de-bounce filter: 40 to 999 Hz maximum input frequency allowed with low speed filter.

**Time Base:** Second, minute, hour, or day

**Gate:** Low gate: 0.1-99.9 seconds; High gate: 2.0-999.9 seconds

## Rate/Totalizer

**Display Assignment:** The main (Big) and small (Little) displays may be assigned to rate, total, grand total, alternate R & T, units, and set point.

**Rate Display Indication:** 0 to 999999, lead zero blanking. "R" LED illuminates while displaying rate.

**Total Display & Total Overflow:** 0 to 999,999; automatic lead zero blanking. "T" LED is illuminated while displaying total or grand total. Up to 999,999,999 with total-overflow feature. "OF" is displayed to the left of total overflow and  $\blacktriangle$  LED is illuminated.

**Alternating Display:** Either display may be programmed to alternate between rate and total or rate and grand total every 10 seconds.

**Total Decimal Point:** Up to five decimal places or none: d.ddddd, d.dddd, d.ddd, d.dd, d.d, or dddddd.

**Totalizer:** Calculates total based on rate and field programmable multiplier to display total in engineering units. Time base must be selected according to the time units in which the rate is displayed.

**Total Conversion Factor:** 0.00001 to 59,999

**Totalizer Rollover:** Totalizer rolls over when display exceeds 999,999,999. Relay status reflects the display value.

**Total Overflow Override:** Program total reset for automatic with 0.1 second delay and set point 1 for 999,999

**Totalizer Presets:** Up to eight, user selectable under Setup menu. Any set point can be assigned to total and may be programmed anywhere in the range of the meter for total alarm indication.

**Programmable Total Reset Delay:** 0.1 to 999.9 seconds; applied to the first relay assigned to total or grand total. If the meter is programmed to reset total to zero automatically when the preset is reached, then a delay will occur before the total is reset.

**Total Reset:** Via front panel button, external contact closure on digital inputs, automatically via user selectable preset value and time delay, or through serial communications.

**Total Reset Password:** Total and grand total passwords may be entered to prevent resetting the total or grand total from the front panel.

**Non-Resettable Total:** The grand total can be programmed as a non-resettable total by entering the password "050873".

*Caution: Once the Grand Total has been programmed as "non-resettable" the feature cannot be disabled.*

## Relays

**Rating:** 2 or 4 SPDT (Form C) internal and/or 4 SPST (Form A) external; rated 3 A @ 30 VDC and 125/250 VAC resistive load; 1/14 HP @ 125/250 VAC for inductive loads

**Noise Suppression:** Noise suppression is recommended for each relay contact switching inductive loads.

**Deadband:** 0-100% of span, user programmable

**Relay Assignment:** Relays may be assigned to rate, total, or grand total.

**High or Low Alarm:** User may program any alarm for high or low trip point. Unused alarm LEDs and relays may be disabled (turned off).

**Relay Operation:** automatic (non-latching), latching (requires manual acknowledge), sampling (based on time), off (disable unused relays), and manual control mode.

**Relay Reset:** User selectable via front panel buttons, digital inputs, or PC

1. Automatic reset only (non-latching), when input passes the reset point or total is reset to zero.
2. Automatic + manual reset at any time (non-latching).
3. Manual reset only, at any time (latching).
4. Manual reset only after alarm condition has cleared (latching).

*Note: Front panel button or digital input may be assigned to acknowledge relays programmed for manual reset.*

**Time Delay:** 0 to 999.9 seconds, on & off relay time delays. Programmable and independent for each relay.

**Fail-Safe Operation:** Programmable and independent for each relay.

*Note: Relay coil is energized in non-alarm condition. In case of power failure, relay will go to alarm state.*

**Isolated 4-20 mA Transmitter Output**

**Output Source:** Rate, total, grand total, max, min, set points 1-8, or manual control mode

**Scaling Range:** 1.000 to 23.000 mA for any display range

**Calibration:** Factory calibrated: 4.000 to 20.000 = 4-20 mA output

**Analog Output Programming:** 23.000 mA maximum for all parameters: Overrange, underrange, max, min, and break

**Accuracy:** ± 0.1% FS ± 0.004 mA

Note: Although the specification above states very high accuracy, it is based in percent. Therefore, the variance when dealing with very large retransmitted numbers such as those that may be associated with the "Total" variable (up to 9 digits with overflow) will grow proportionately.

**Temperature Drift:** 0.005% of calibrated span/°C max from 0 to 65°C ambient, 0.01% of calibrated span/°C max from -40 to 0°C ambient  
Note: Analog output drift is separate from input drift.

**Isolated Transmitter Power Supply:** Terminals I+ & R: 24 VDC ± 10% @ 40 mA maximum, may be used to power the 4-20 mA output or other devices. Present on both AC & DC powered units.

**External Loop Power Supply:** 35 VDC maximum

**Output Loop Resistance:**

Power supply	Minimum	Maximum
24 VDC	10 Ω	700 Ω
35 VDC (external)	100 Ω	1200 Ω

**Serial Communications**

**Meter Address:** 1 - 247

**Baud Rate:** 300 - 19,200 bps

**Transmit Time Delay:** Programmable between 0 and 199 ms or transmitter always on for RS-422 communication

**Data:** 8 bit (1 start bit, 1 stop bit)

**Parity:** None

**Turn Around Delay:** Less than 2 ms (fixed)

**Digital I/O Expansion Module**

**Channels:** 4 digital inputs & 4 digital outputs per module

**System:** Up to 2 modules for a total of 8 inputs & 8 outputs

**Digital Input Logic: High:** 3 to 5 VDC **Low:** 0 to 1.25 VDC

**Digital Output Logic: High:** 4.75 to 5 VDC **Low:** 0 to 0.4 VDC

**Source Current:** 10 mA maximum

**Sink Current:** 1.5 mA minimum

**+5 V Terminal:** To be used as pull-up for digital inputs only. Example: Connect normally open pushbuttons across +5 V & DI1-4.

**4-Relay Expansion Module**

**Relays:** Four Form A (SPST) rated 3 A @ 30 VDC and 125/250 VAC resistive load; 1/14 HP @ 125/250 VAC for inductive loads.



**Disclaimer**

The information contained in this document is subject to change without notice. Precision Digital Corporation makes no representations or warranties with respect to the contents hereof, and specifically disclaims any implied warranties of merchantability or fitness for a particular purpose. ©2009 Precision Digital Corporation. All rights reserved.

**ORDERING INFORMATION**

ProVu • Model PD6200 Analog Inputs		
85-265 VAC Model	12/24 VDC Model	Options Installed
PD6200-6R0	PD6200-7R0	None
PD6200-6R2	PD6200-7R2	2 Relays
PD6200-6R3	PD6200-7R3	4-20 mA Output
PD6200-6R4	PD6200-7R4	4 Relays
PD6200-6R5	PD6200-7R5	2 Relays & 4-20 mA Output
PD6200-6R7	PD6200-7R7	4 Relays & 4-20 mA Output

Note: 24 V flowmeter power supply standard on all models.

ProVu • Model PD6300 Pulse Inputs		
85-265 VAC Model	12/24 VDC Model	Options Installed
PD6300-6R0	PD6300-7R0	None
PD6300-6R2	PD6300-7R2	2 Relays
PD6300-6R3	PD6300-7R3	4-20 mA Output
PD6300-6R4	PD6300-7R4	4 Relays
PD6300-6R5	PD6300-7R5	2 Relays & 4-20 mA Output
PD6300-6R7	PD6300-7R7	4 Relays & 4-20 mA Output

Note: 24 V flowmeter power supply standard on all models.

Accessories	
Model	Description
PDA1002	DIN Rail Mounting Kit for Two Expansion Modules
PDA1004	4-Relay Expansion Module
PDA1044	4 Digital Inputs & 4 Digital Outputs Module
PDA1200	Meter Copy Cable
PDA1232	RS-232 Serial Adapter
PDA1485	RS-422/485 Serial Adapter
PDA7485-I	RS-232 to RS-422/485 Isolated Converter
PDA7485-N	RS-232 to RS-422/485 Non-Isolated Converter
PDA8232-N	USB to RS-232 Non-Isolated Converter
PDA8485-I	USB to RS-422/485 Isolated Converter
PDA8485-N	USB to RS-422/485 Non-Isolated Converter
PDX6901	Suppressor (snubber): 0.01 µF/470 Ω, 250 VAC
PDA2811	NEMA 4X Enclosure for 1 Meter
PDA2812	NEMA 4X Enclosure for 2 Meters

See [www.predig.com](http://www.predig.com) for additional enclosures.

**Your Local Distributor is:**



**M&D CONTROLS, INC**  
 4142 South 70<sup>th</sup> East Avenue  
 Tulsa, Oklahoma 74145-4605  
 Tulsa - (918)664-7511 Fax (918)622-7035 WATS 800-824-3818  
 email- [mddcontrols@aol.com](mailto:mddcontrols@aol.com)